

Bunsen Burner Basics

Introduction

Bunsen burners are used to provide a safe heat source during many laboratory experiments. Before using a Bunsen burner in an experiment, it is important to review the proper techniques of lighting, adjusting, and safely using a Bunsen burner.

Concepts

- Laboratory safety
- Bunsen burners
- Combustion

Bunsen Burner Background

Bunsen burners were developed by Robert Bunsen and Peter Desaga in 1855. Bunsen needed a reliable burner for his new laboratory at the University of Heidelberg and designed a burner that mixed air with the gas before combustion. Most of the gas burners and lights available in the 1800s mixed the gas and air at the combustion site.

The Bunsen burner uses the combustion of methane (also called natural gas) and oxygen according to Equation 1 to produce heat. If enough oxygen is available, roughly two moles of oxygen for each mole of methane, then complete combustion will occur and maximum heat (flame) will be produced. If the amount of oxygen is deficient, then incomplete combustion (Equation 2) will occur and carbon (also called soot) and carbon monoxide will also be formed. Less heat is produced during incomplete combustion. Mixing air with the gas before combustion ensures that enough oxygen will be available and complete combustion will occur.



The modern Bunsen burner has changed very little from Robert Bunsen's original design. It consists of a base, a gas inlet, the gas jet, the air control vent with a collar for adjusting the air flow, the barrel, and the mouth of the tube (Figure 1).

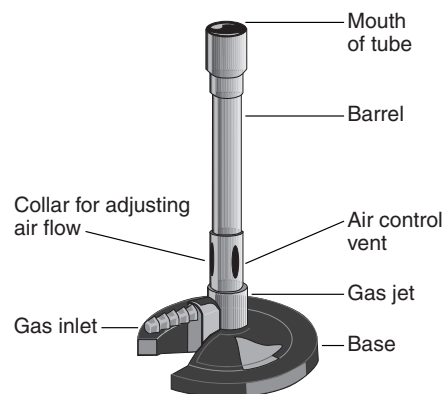

Figure 1.

Procedure for Lighting a Bunsen Burner

1. Clear off the lab bench. Remove all flammable and combustible materials from the work area.
2. Connect rubber tubing to the lab burner gas inlet and gas valve. Check for holes or cracks in the tubing.
3. Close or partially close the air vents on the burner to make it easier to light.
4. Obtain matches, a piezo lighter, or striker (also called a flint lighter). If using matches or a lighter, light it now.
5. Turn on the gas.
6. Bring the lit match (or lighter) along side the barrel of the burner and raise it slowly over the edge of the barrel from the side (see Figure 2). If using a flint lighter, hold it slightly off center of the barrel of the burner and a few inches above the tip. Strike the flint lighter to create a spark over the gas coming out of the burner.
7. After the burner is lit, thoroughly extinguish the match with water.
8. A lit Bunsen burner with closed or partially closed air vents gives a yellow safety flame. Closing the air vents makes it easier to light the Bunsen burner and to observe the flame. The soft yellow flame should never be used to heat anything.

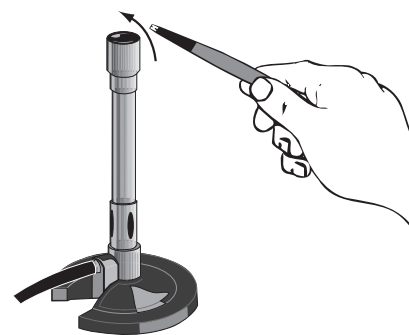

Figure 2.

- Adjust the air supply by turning the metal collar to get a tight, bright blue, cone-shaped flame. This is a very hot flame (see Figure 3 for a temperature profile of various parts of a flame).
- Never leave a lit burner unattended.
- Turn off the gas at the gas source when finished using the Bunsen burner.

Safety Rules for Using Bunsen Burners and Heating Substances

- Only use the Bunsen burner when specifically instructed to use it during an experiment authorized by the instructor.
- Never turn on the gas unless instructed by your instructor.
- Always light the match or lighter before turning on the gas.
- Always inspect the Bunsen burner, tubing, and gas valve before using the burner.
- Always follow proper procedures for lighting and using a Bunsen burner (see procedure).
- Tie back long hair and do not wear loose long sleeves. Take care that hair, clothing, and hands are a safe distance away from the flame at all times. Never reach over an exposed flame.
- Use tongs when holding objects in a flame.
- Never leave a lit Bunsen burner unattended. Never leave anything that is being heated unattended.
- Always turn the Bunsen burner off when it is not in use.
- Always wear chemical splash goggles whenever chemicals, glassware, or heat are used.
- Exercise extreme caution when using a Bunsen burner. Be sure all flammable liquids and combustible papers are removed from the area.
- Hot metal and glass remain very hot for a very long time. They should be set aside to cool and picked up with caution.
- Never look into a test tube or container being heated. Never point the open end of a test tube being heated towards anyone.
- The barrel of the Bunsen burner may remain hot for some time after the burner has been used. Carefully check to make sure the burner has cooled before moving it or putting it away.

Using a Bunsen Burner

When the air vent of a Bunsen burner is closed, air for the combustion reaction is only coming from the area near the top of the burner. As a result, incomplete combustion occurs and elemental carbon is produced. The temperature of the flame is lower and it is a bright yellow, candle-like flame. The yellow flame is called a luminous flame and is very similar to a candle or gas-light flame. It is also a quiet flame that is greatly affected by air currents, much like a candle. The flame is also called a yellow safety flame because it is a cooler flame and makes the burner easier to light.

Increasing the air flow to the burner produces more complete combustion and a hotter flame. The air is increased by opening up the air vent (turning the metal collar). The air is drawn into the barrel of the burner by the gas coming out of the gas jet. The gas-air mixture is then ignited above the barrel. The result is a noisy, bluish-colored, three-cone flame. This blue flame provides the highest possible temperature from the burner. The temperature varies greatly across the three major regions of the flame, as shown in Figure 3. The hottest part of the flame is just above the inner blue cone (see Figure 3).

Sometimes when the air flow is being adjusted, the flame may “blow out.” If this happens, simply turn off the gas and close the air vent. Wait 30 seconds for the burner to slightly cool and then follow the proper procedures for lighting the Bunsen burner. If the flame continually “blows out,” try turning the gas pressure down a little.

The flame can also be adjusted by adjusting the gas flow. Major adjustments in gas flow are made

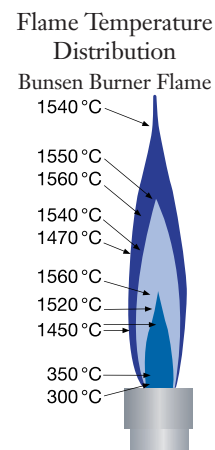

Figure 3.

by turning the handle on the natural gas valve. The height and intensity of the Bunsen burner flame depend on both the gas flow and the amount of air available for combustion. If either of these two gases is too high, the flame will continually “blow out.” If this happens, turn off the gas and close the air vents, allow the burner to cool for 30 seconds, and relight the burner with less gas and air pressure.

A Tirrill burner is similar to a Bunsen burner but it has a brass needle valve below the gas jet to regulate the gas supply. Minor gas adjustments can be made by turning this valve. A Meker burner is a high temperature burner that has a much larger burner mouth. The Meker burner mouth has a screen that forms many short, small, uniform blue flame cones. These multiple flame cones reach temperatures closer to 1750 °C.

Connecting to the National Standards

This laboratory activity relates to the following National Science Education Standards (1996):

Unifying Concepts and Processes: Grades K–12

Form and function

Content Standards: Grades 5–8

Content Standard F: Science in Personal and Social Perspectives; personal health.

Content Standard G: History and Nature of Science

Content Standards: Grades 9–12

Content Standard F: Science in Personal and Social Perspectives; personal and community health; natural and human-induced hazards

Content Standard G: History and Nature of Science

Materials for *Bunsen Burner Basics* are available from Flinn Scientific, Inc.

Catalog No.	Description
AP1017	Bunsen Burner, Natural Gas
AP5344	Bunsen Burner, Adjustable, Natural Gas
AP1024	Bunsen Burner, Micro
AP1019	Tirrill Burner, Natural Gas
AP1021	Meker Burner, Natural Gas
AP1602	Bunsen Burner Tubing Connector
AP8346	Flint Striker Lighter
AP8960	Butane Safety Lighter
AP1576	Piezo Lighter

Consult your *Flinn Scientific Catalog/Reference Manual* for current prices.

Bunsen Burner Quiz

1. Label the parts of the Bunsen burner.

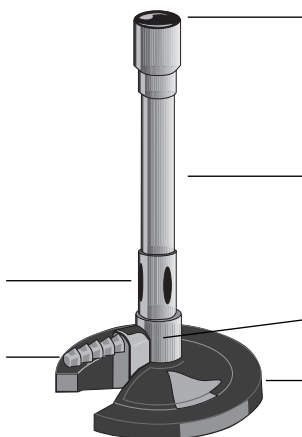

2. Draw a diagram of a correct Bunsen burner flame and label the hottest spot.

3. List three (3) safety rules when lighting a Bunsen burner.

- 1.
- 2.
- 3.

4. List three (3) safety rules when using a Bunsen burner.

- 1.
- 2.
- 3.

5. What is the chemical reaction that occurs for the complete combustion of natural gas.

6. Why is a Bunsen burner flame hotter than a normal gas flame?